

**REFRIGERATOR MANUFACTURER**  
**Turbo air**  
 more durable, efficient, beautiful

4184 E. Conant St.  
 Long Beach, CA 90808  
 Tel. 310-900-1000  
 Fax. 310-900-1077  
[www.turboairinc.com](http://www.turboairinc.com)

Project :	
Model # :	
Item # :	Qty :
Available W/H :	
Approval :	

## Swing Door Freezers

Glass Door Merchandisers  
 Freezers

**Model : TGF-72F(B)**

### FEATURES & BENEFITS

- **Self-cleaning condenser device** *Only at Turbo Air*  
 The accumulation of dust in the condenser causes the failure or breakdown of refrigerators. Refrigerators run normally until they reach a certain level of accumulation. At some point, when they are over the limit, their performance drops quickly resulting in damage to, or disposal of the stored products in refrigerators. The self-cleaning condenser device keeps the condenser clean and prevents system failure by automatically brushing daily.
- **Digital temperature control & monitor system**

  - Keep food products safe by maintaining constant temperatures.
  - Alarms that sound when doors are not sealed shut; protect against food spoilage that originate from cold air leaks.
  - Digital display allows for easy monitoring.
  - Programs interpret the condition of refrigeration systems by self-diagnosis.
  - Smart fuzzy defrost system.
  - Automatic evaporator fan motor delays.
- **Individual two cycle refrigeration systems**
- **LED advertising panel**  
 LED lighting offers 5 times longer lasting life than fluorescents and conserves energy as well.
- **LED lighting interior**
- **Efficient refrigeration system**  
 Turbo Air's freezers are designed with oversized and balanced (CFC Free R-404A) refrigeration systems. These include efficient evaporators and condensers for faster freezing and greater efficiency.
- **Triple pane heated glass doors**  
 Equipped with unique triple-pane heated glass doors which enhance energy efficiency by preventing heat transfers and minimizing condensation. Lightweight door construction reduces door maintenance, bushing wear, and facilitates smooth door opening.
- **High-density polyurethane insulation**  
 The entire cabinet structure is foamed-in-place using high density, CFC free polyurethane insulation.
- **Ergonomically designed doors**  
 Customers' fatigue fades away with easy grip handles and doors that open effortlessly. These features along with self-closing doors make this the ultimate choice in customer convenience.
- **Adjustable, heavy duty, PE (polyethylene) coated wire shelves**
- **Freezer holds -10°F ~ 5°F for the best in frozen food preservation**



TGF-72FB



TGF-72F

**Self-Cleaning  
 Condenser**



**NO MAINTENANCE REQUIRED**



Model	Swing Door	CU./FT.	#of Shelves	HP	AMPS	Crated Weight (lbs.)	L x D x H (inches)
TGF-72F(B)	3	72	12	1 1/4 x 2	15	848	81 7/8 x 29 3/4 x 78 1/4

## Model : TGF-72F(B)

ELECTRICAL DATA	
Voltage †	115/208~230/60/1
Plug Type †	☺ NEMA L14-20
Full Load Amperes / LRA	15 / 34
Compressor HP	1 1/4 x 2
Cord Length (ft.)	7
Refrigerant	R-404A
DIMENSIONAL DATA	
# of Doors	3
Net Capacity (cu. ft.)	72
Ext. Length Overall (in.)	81 7/8 (2079mm)
Ext. Depth Overall (in.)*	29 3/4 (756mm)
Ext. Height Overall (in.)	78 1/4 (1987mm)
Int. Length Overall (in.)	78 (1981mm)
Int. Depth Overall (in.)	24 1/8 (614mm)
Int. Height Overall (in.)	60 3/8 (1535mm)
Net Weight (lbs.)	800
Gross Weight (lbs.)	848
# of Shelves	12
Shelf Size (L x D) (in.)	25 x 22 1/4

Design and specifications subject to change without notice.  
Actual shipping weight may differ due to extra packing materials for product protection.  
\* Depth does not include 1-3/8" for glass door handles.  
† TGF-72F requires dual voltage 115/208~230V (NEMA L14-20)

■ **WARRANTY : 2 Year Parts and Labor Warranty  
Additional 3 Year Warranty on Compressor**

- **Magnetic door gaskets**
- **White and black color come standard**
- **4" dia. swivel casters available (optional)**
- **Price tag channel available (optional)**

■ **OPTIONAL ACCESSORIES :**

- 4" caster, 1/2" diameter & 13 TPI: G8F6500101 (non-brake), G8F6500201 (w/ brake)
- Additional PE coated wire shelf: 30278R0301
- Price tag channel: P0122K5300 (24 1/2"L)

## PLAN VIEW

(unit : inch)

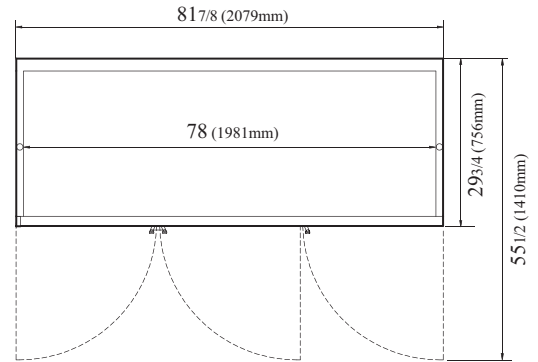

PLAN VIEW

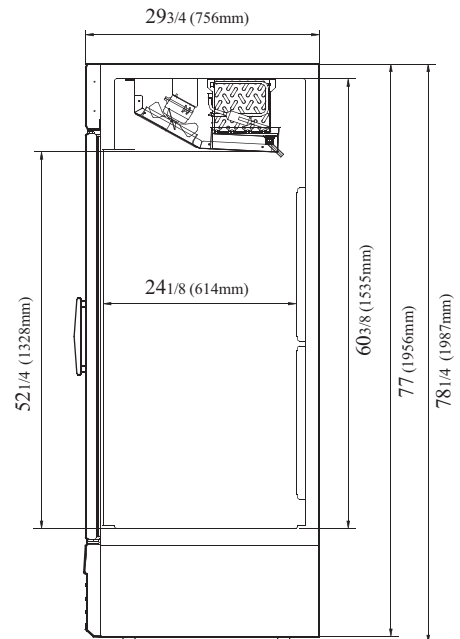

SIDE VIEW

Ver.201602



- Turbo Air : 800-627-0032
- GK : 800-500-3519
- Warranty : 800-381-7770
- AC : 888-900-1002